

VOUGE PENDANT

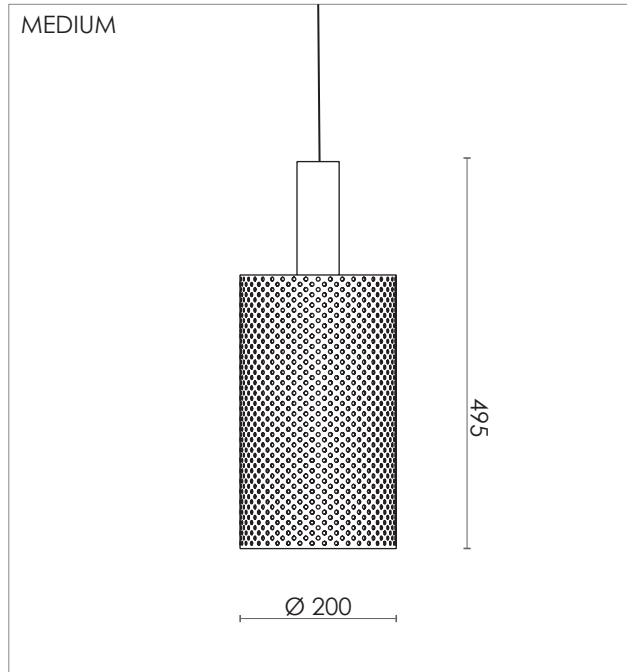

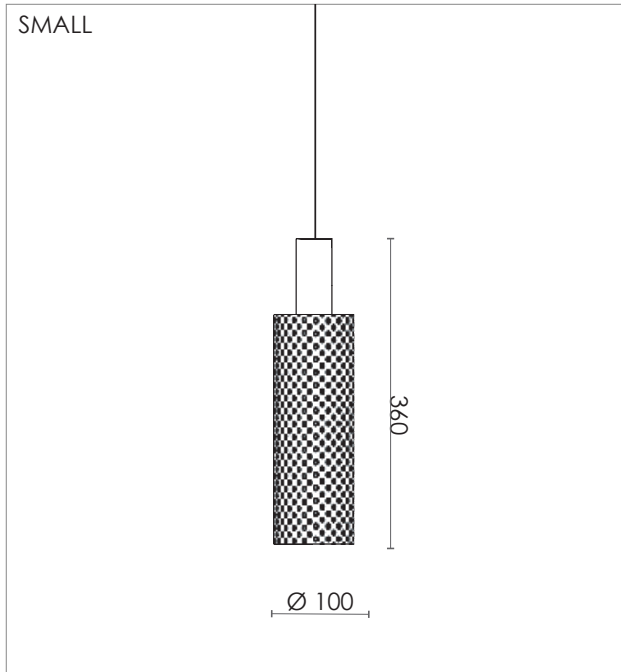

DESIGN SPECIFICATIONS

DIMENSIONS (mm)	W Ø 100 x H 360 W Ø 200 x H 495
WEIGHT (kg)	1,1 / 2,8 / 4,8
MATERIALS	THE LAMP IS MADE FROM CLEAR LACQURED BRASS OR POWDER COATED STEEL
CORD (mm)	BLACK TEXTILE - L 3700
ENVIRONMENT	INDOOR
DESIGN BY	NICLAS HOFLIN
DESIGN YEAR	2015

ELECTRICAL SPECIFICATIONS

SWITCH	NO
BULB HOLDER	E27
LIGHT SOURCE	INCLUDED DIMMABLE 6 W LED - 2700K
DIMMABLE	YES
MAX (W)	12 W LED
VOLTAGE	230 / 240
CLASS	1
IP	20

COLOURS

	BLACK/ BRASS	SMALL ART.NO. 511571005	MEDIUM ART.NO. 5115740051
	WHITE/ BRASS	SMALL ART.NO. 511571303	MEDIUM ART.NO. 511574303
	BRONZE- COLOR/ BLACK	SMALL ART.NO. 511571223	MEDIUM ART.NO. 511574223